

0102

Introduction

PT Indigo was founded in 1998 as a limited liability foreign investment company in Jakarta, Indonesia.

Initially Indigo designed, developed and managed the production of new and innovative products, aimed at the export market and manufactured in cooperation with local industries.

In 2004 we ventured out into signage and graphic design. Nowadays we are one of the leading signage consultants in Indonesia. Our experienced and multidisciplinary team consisting of product- and graphic designers, architects, 3d artists and planners is capable of producing innovative and holistic design solutions for branding and signage projects in various property sectors. Currently our projects are located in both Indonesia and the South East Asia region.



Our Field of Work

Our main focus is on Asia's growing property industry.

Our client base includes both local and international project developers and we provide our services to the hospitality, office, commercial, mixed use, public transport, landed housing, high rise residential, health-care and F&B sector. Each of these sectors present their own unique challenges and require a different approach.



← WHIRLPOOL
← INDOOR SWIMMING POOL

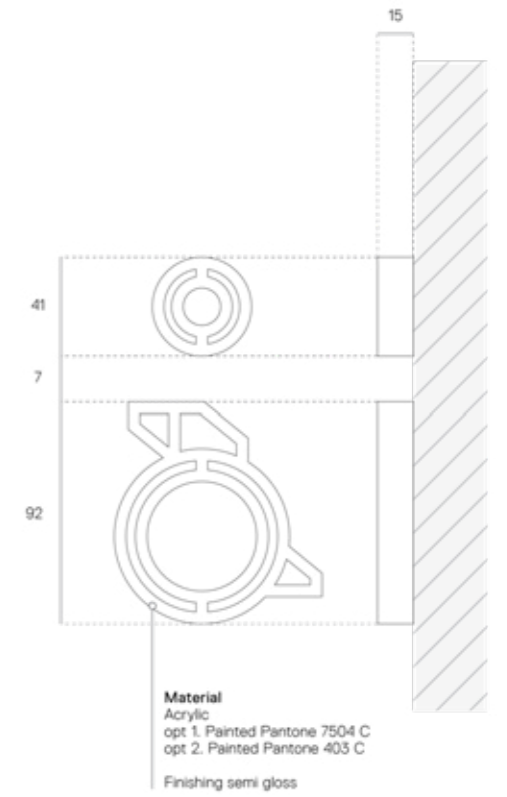
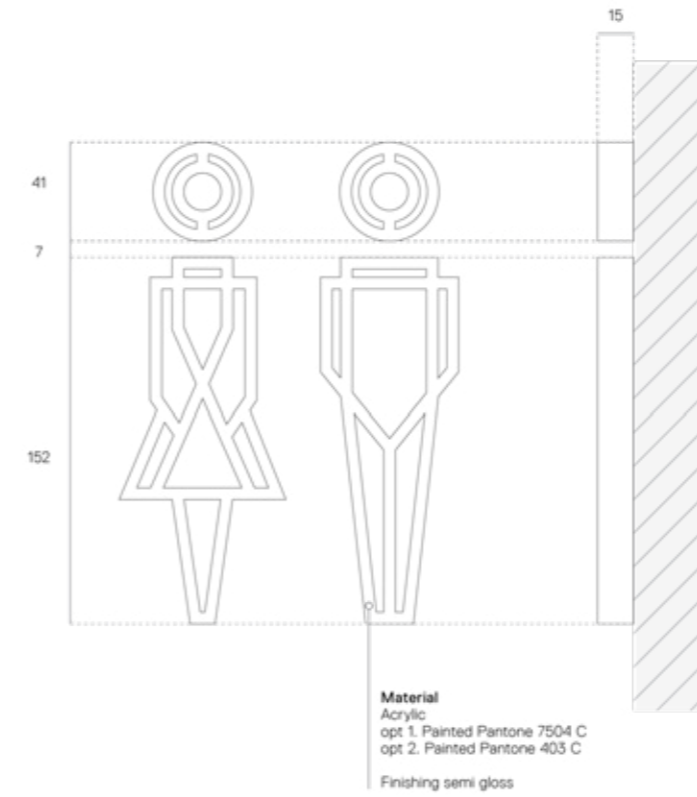



Our Services

Indigo provides integrated design and consultancy services including; visual branding, signage, wayfinding, environmental graphics and public facilities.

Depending on the nature of the project and the client's requirements we can create a new identity from ground up, or assist clients with the implementation of existing brand, and signage guidelines.

We work in close cooperation with project owners and their appointed project team of (interior) architects, lighting, MEP, and landscape consultants as well as hotel, hospital, and F&B operators.

VISUAL BRANDING

- Analysis of the project
- Concept proposals for brand naming and visual identity
- Logo design
- Production of brand guidelines
- Design of graphic collateral
- Design of environmental graphics
- Special projects (mosaics, carpet designs)

SIGNAGE, WAYFINDING & PUBLIC FACILITIES

- Analysis of site plans
- Analysis of existing brand and signage guidelines
- Keyplans for signage locations
- Bill of quantity
- Cost estimation
- Concept proposals for signage design
- Production of 2D and 3D design presentations
- Material and production specifications
- Technical drawings
- Production of graphic content
- Site survey
- Mockup reviews
- Tender assistance
- Technical advise to contractors





Visual Branding

Design of graphic identities for property, F&B and other projects.

Depending on the clients preference, we can design an entire new identity from ground up, or implement existing brand-, and/or signage-guidelines provided by the client or the appointed operator. In many cases we have developed brand identities for our clients, including naming, design of the logo, colour schemes, brand specific patterns and the implementation hereoff into specific collateral such as menus and hotel amenities.

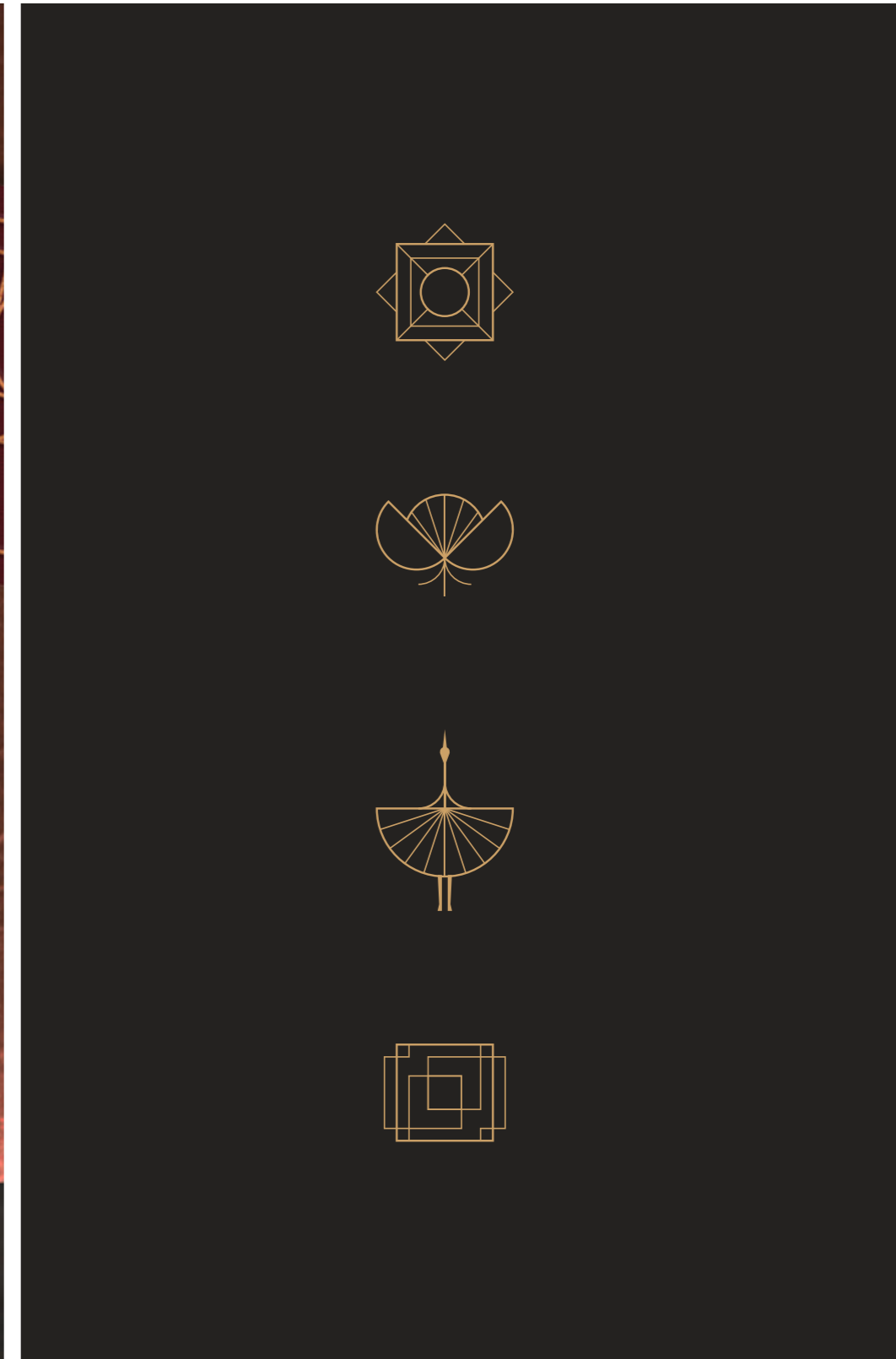

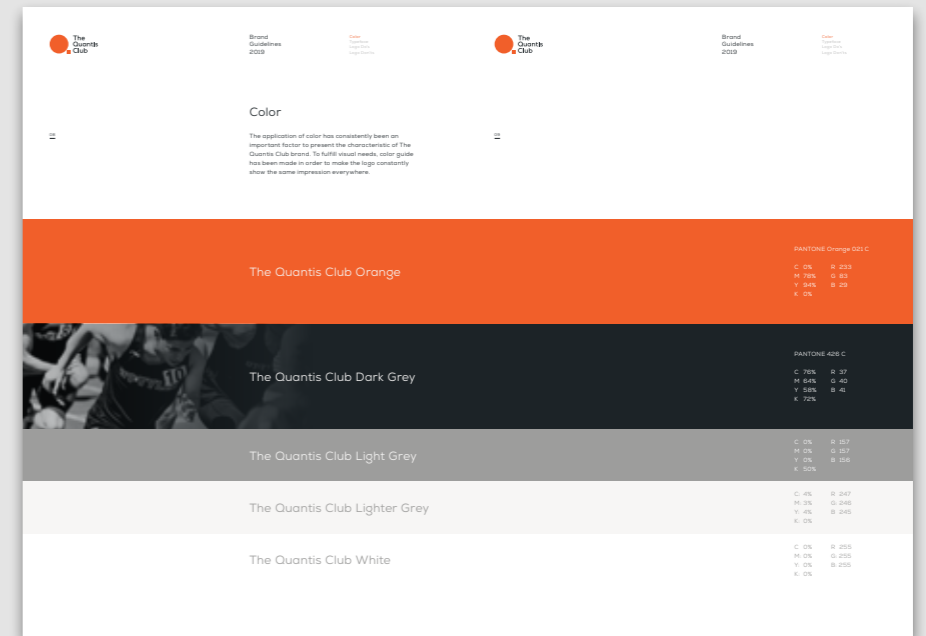
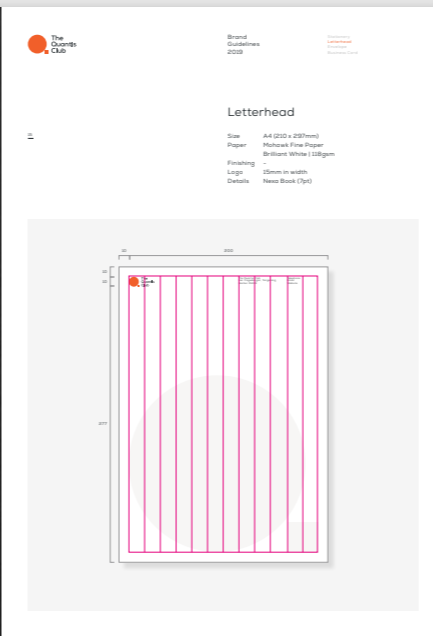
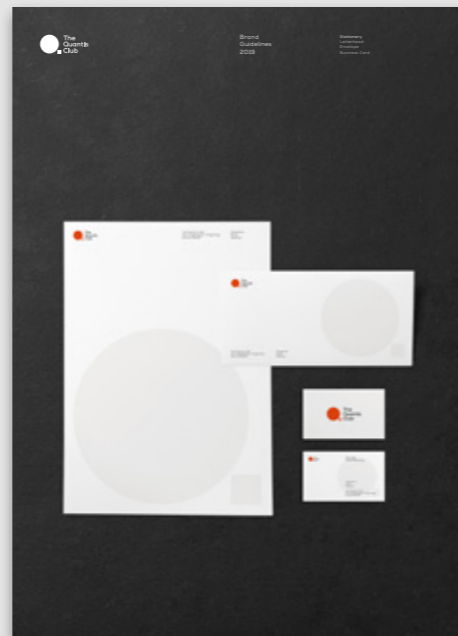
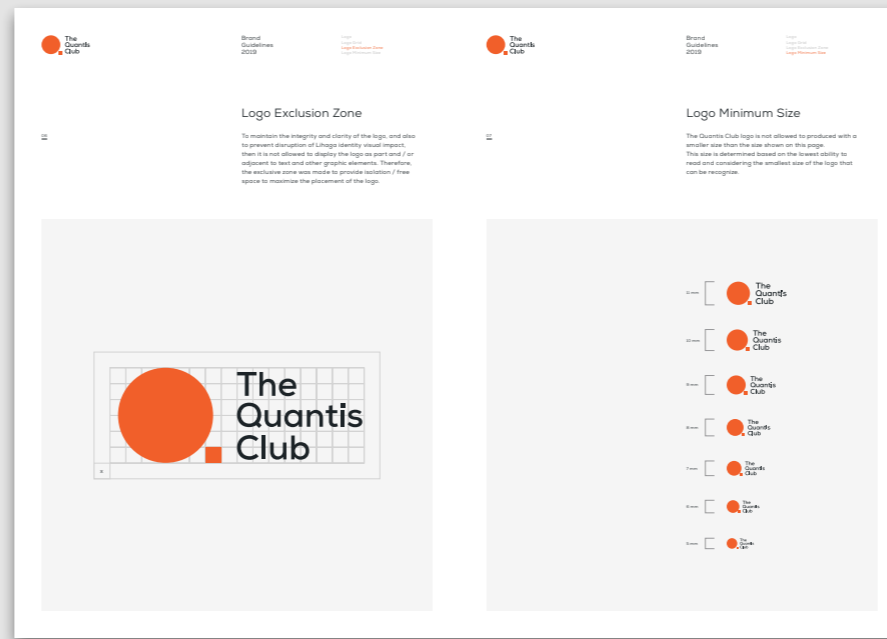
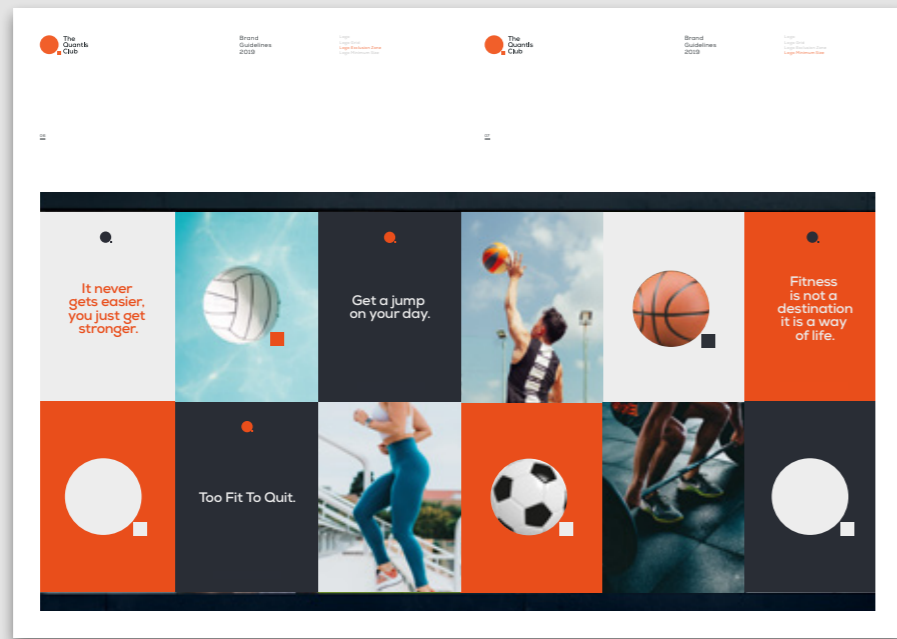
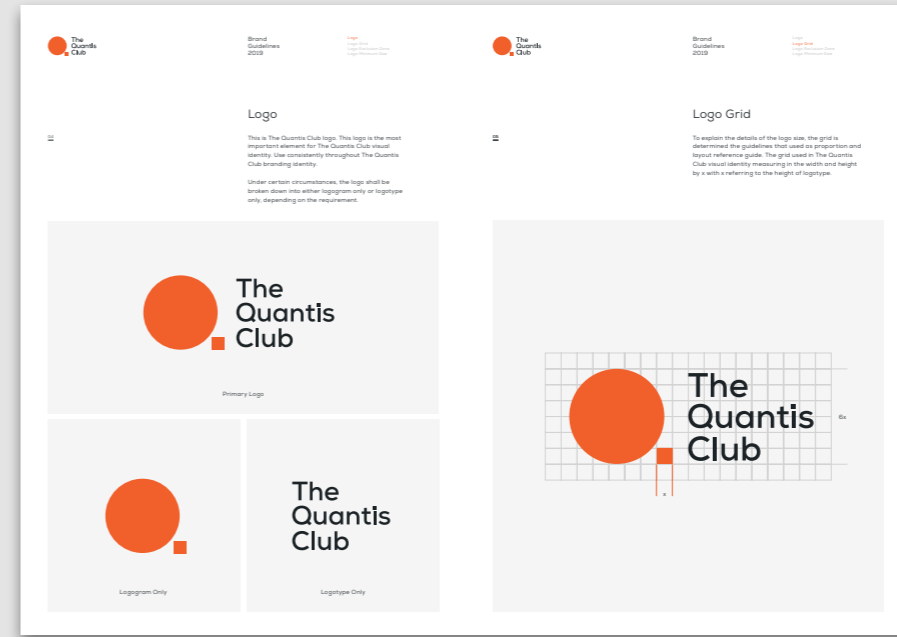
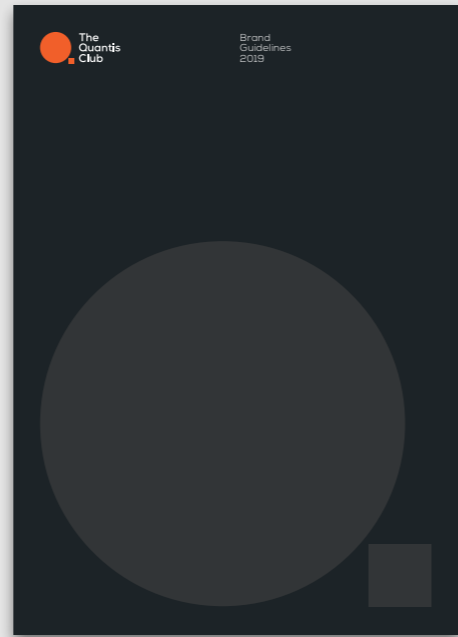

Signage

Our extensive experience in signage design includes both interior and exterior signage.

One day we are advising on the structural aspects of mounting an 8 meter tall facade sign at the top of a building, the next we are designing a room number with integrated bell and do-not-disturb light. Our typical signage project includes creating concepts, implementing brands, assuring proper way finding, and placement of signs, production of graphic content, selecting material and assisting clients and contractors with production and installation.

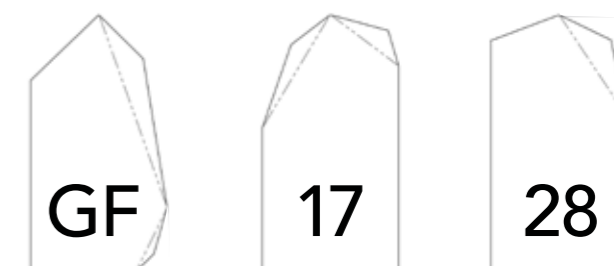



DISTRICT 8 OFFICES, JAKARTA, 2018



DISTRICT 8 OFFICES, JAKARTA, 2018



SWISSOTEL, JAKARTA, 2016





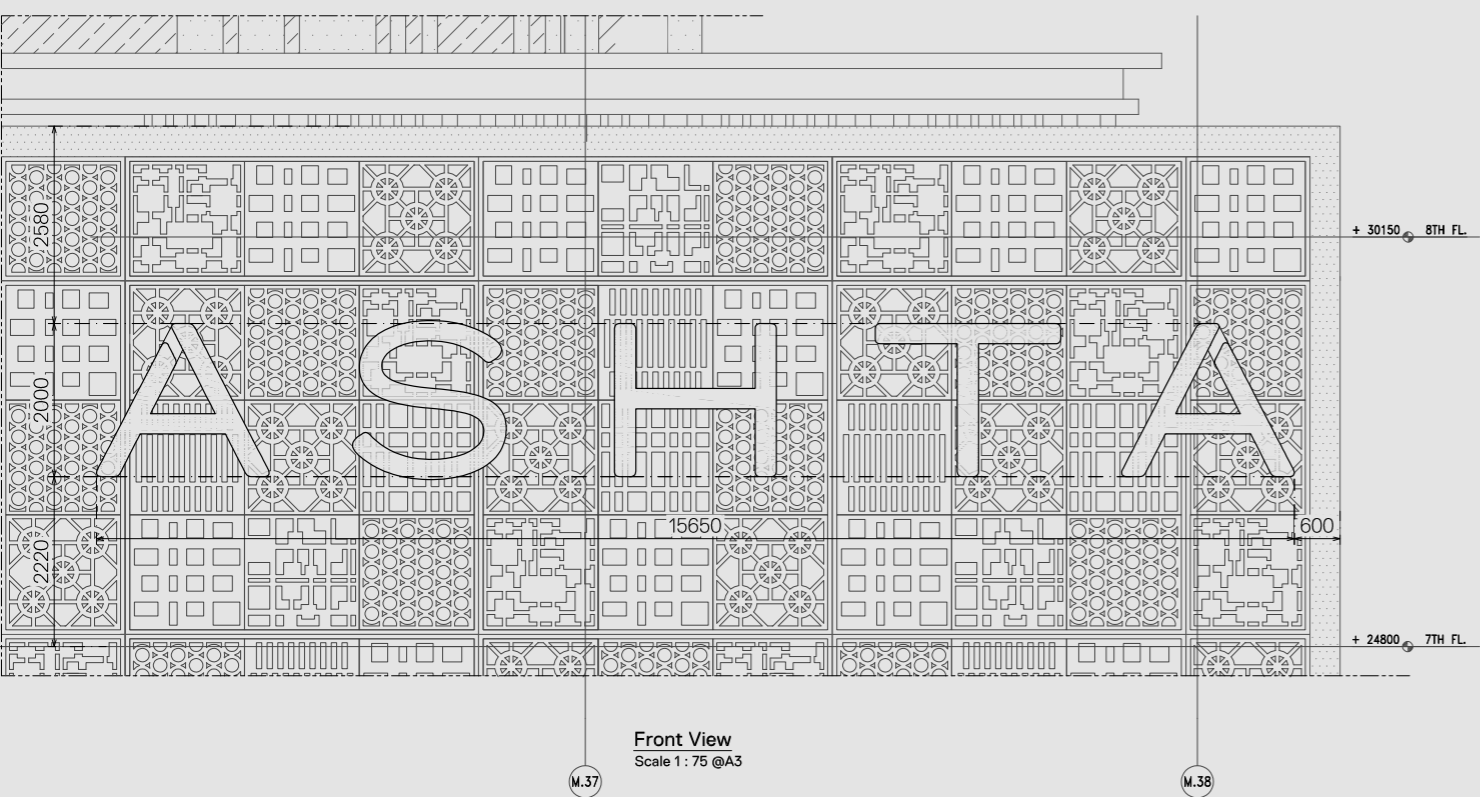

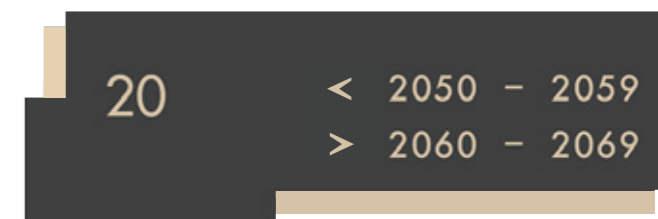

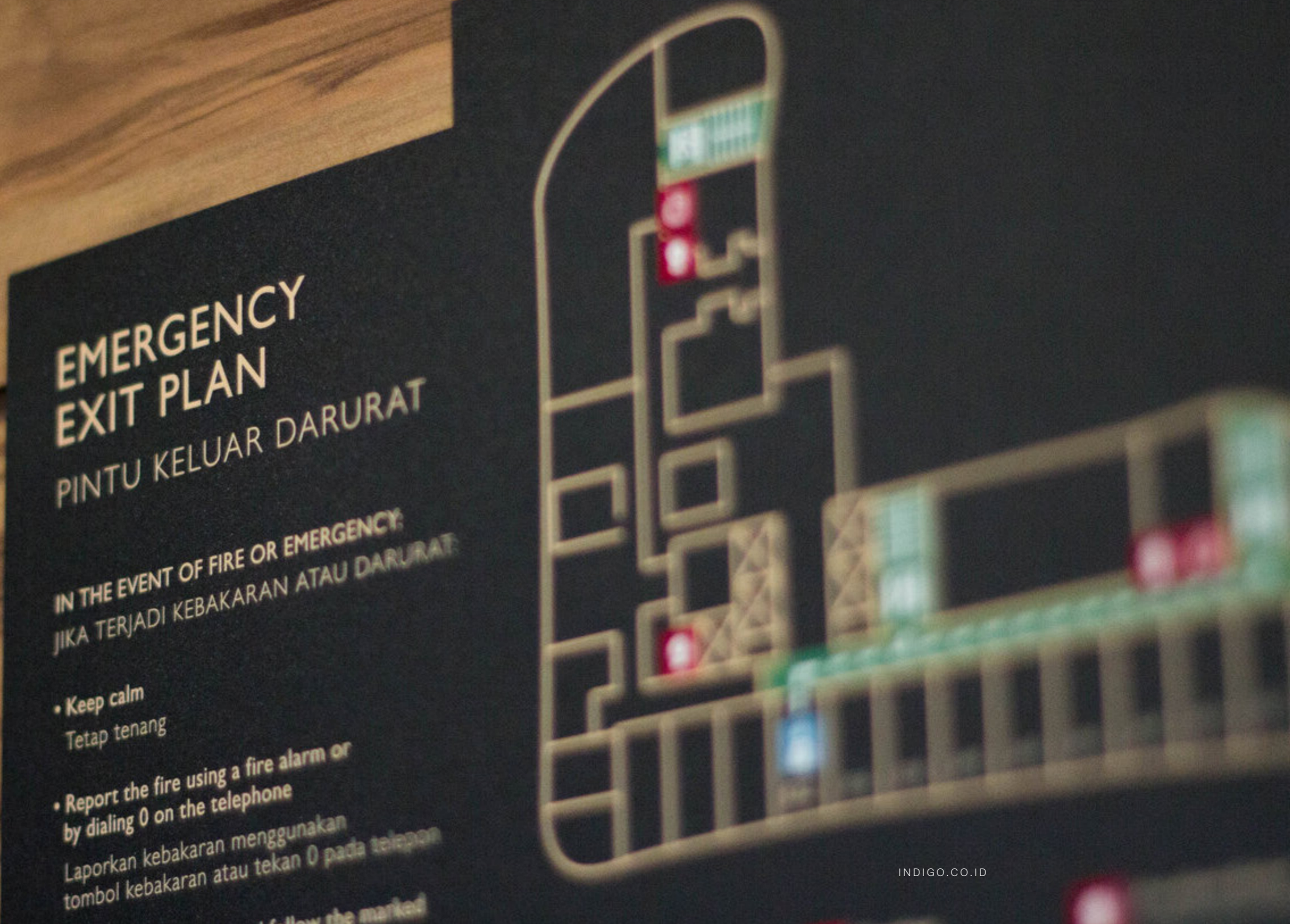

**EMERGENCY
EXIT PLAN**
PINTU KELUAR DARURAT

IN THE EVENT OF FIRE OR EMERGENCY:
JIKA TERJADI KEBAKARAN ATAU DARURAT:

- Keep calm
Tetap tenang
- Report the fire using a fire alarm or
by dialing 0 on the telephone
Laporkan kebakaran menggunakan
tombol kebakaran atau tekan 0 pada telepon
- Follow the marked



Wayfinding

For Jakarta's MRT we produced extensive guidelines for all (way-finding) graphics, in cooperation with Transport Design, based in the UK.

The guidelines include an extensive symbol library, recommended font sizes, use of colours and symbols, principles of correct placement for signs and hierarchy in information. In a separate project we have designed signage hardware and implemented the guidelines in a selected number of stations. The implementation included the production of key plans, graphic content and technical drawings.

5.19

Kontrol garis luar
Semua elemen grafis harus dibuat dengan ketepatan yang tinggi. Untuk memastikan hal ini, setiap elemen grafis harus dibuat dengan ketepatan yang tinggi. Untuk memastikan hal ini, setiap elemen grafis harus dibuat dengan ketepatan yang tinggi.

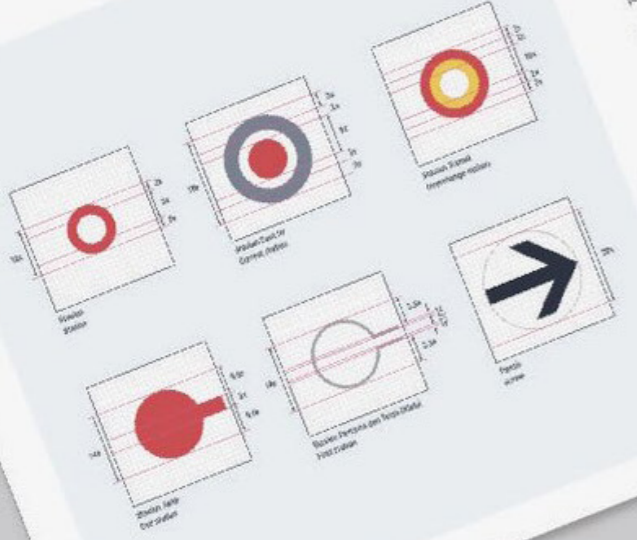

Use flag construction
Untuk memastikan ketepatan dan keselarasan, setiap elemen grafis harus dibuat dengan ketepatan yang tinggi. Untuk memastikan hal ini, setiap elemen grafis harus dibuat dengan ketepatan yang tinggi.

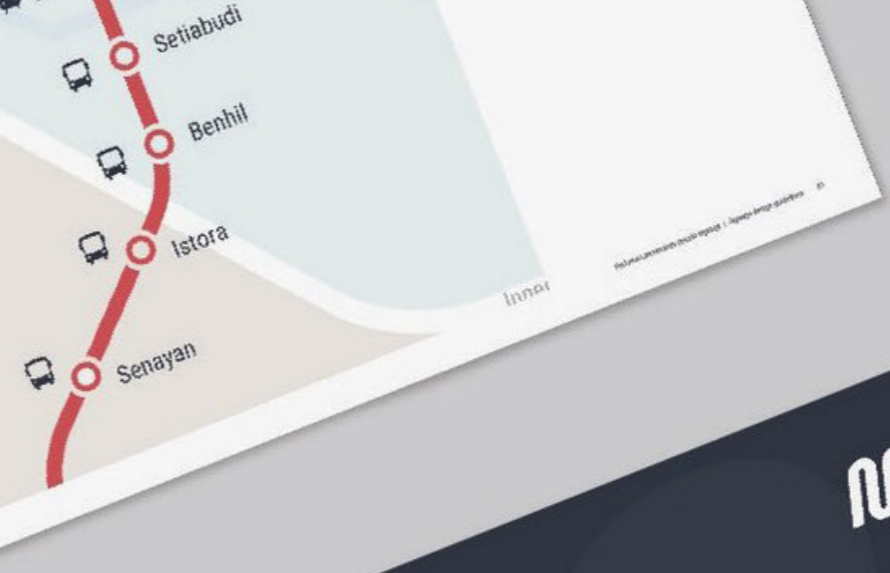

Mass Rapid Transit Jakarta Pedoman pembuatan desain signage / Signage design guidelines

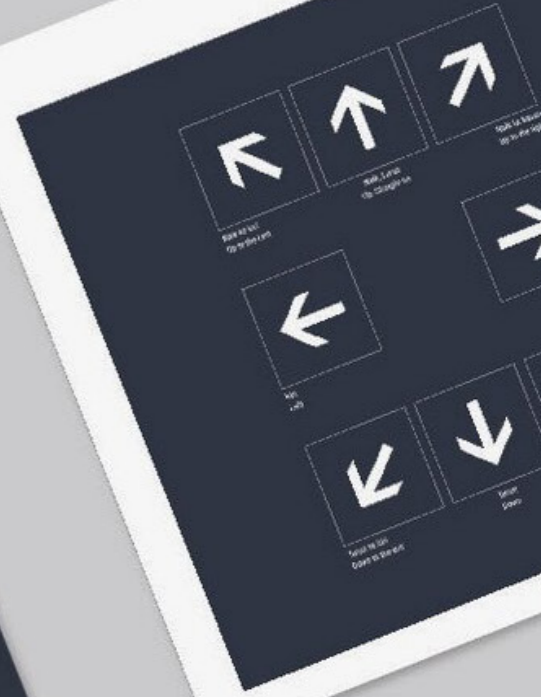

1.2

Cara Menggunakan Panduan ini
Panduan ini adalah panduan yang harus diikuti oleh semua pihak yang terlibat dalam pembuatan desain signage. Untuk memastikan hal ini, setiap elemen grafis harus dibuat dengan ketepatan yang tinggi.

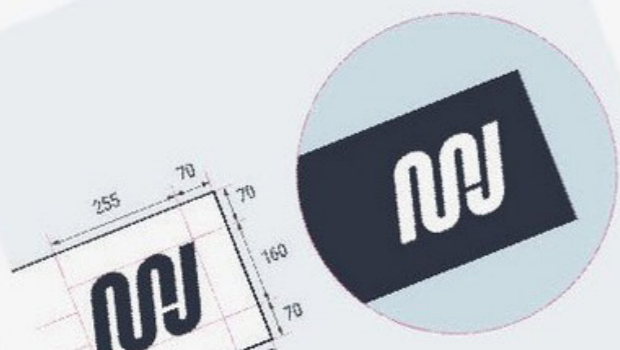

9.23



Contents

1.1	1.1.1	1.1.2	1.1.3	1.1.4	1.1.5	1.1.6	1.1.7	1.1.8	1.1.9	1.1.10	1.1.11	1.1.12	1.1.13	1.1.14	1.1.15	1.1.16	1.1.17	1.1.18	1.1.19	1.1.20	1.1.21	1.1.22	1.1.23	1.1.24	1.1.25	1.1.26	1.1.27	1.1.28	1.1.29	1.1.30	1.1.31	1.1.32	1.1.33	1.1.34	1.1.35	1.1.36	1.1.37	1.1.38	1.1.39	1.1.40	1.1.41	1.1.42	1.1.43	1.1.44	1.1.45	1.1.46	1.1.47	1.1.48	1.1.49	1.1.50	1.1.51	1.1.52	1.1.53	1.1.54	1.1.55	1.1.56	1.1.57	1.1.58	1.1.59	1.1.60	1.1.61	1.1.62	1.1.63	1.1.64	1.1.65	1.1.66	1.1.67	1.1.68	1.1.69	1.1.70	1.1.71	1.1.72	1.1.73	1.1.74	1.1.75	1.1.76	1.1.77	1.1.78	1.1.79	1.1.80	1.1.81	1.1.82	1.1.83	1.1.84	1.1.85	1.1.86	1.1.87	1.1.88	1.1.89	1.1.90	1.1.91	1.1.92	1.1.93	1.1.94	1.1.95	1.1.96	1.1.97	1.1.98	1.1.99	1.1.100
-----	-------	-------	-------	-------	-------	-------	-------	-------	-------	--------	--------	--------	--------	--------	--------	--------	--------	--------	--------	--------	--------	--------	--------	--------	--------	--------	--------	--------	--------	--------	--------	--------	--------	--------	--------	--------	--------	--------	--------	--------	--------	--------	--------	--------	--------	--------	--------	--------	--------	--------	--------	--------	--------	--------	--------	--------	--------	--------	--------	--------	--------	--------	--------	--------	--------	--------	--------	--------	--------	--------	--------	--------	--------	--------	--------	--------	--------	--------	--------	--------	--------	--------	--------	--------	--------	--------	--------	--------	--------	--------	--------	--------	--------	--------	--------	--------	--------	--------	--------	---------



Public Facilities

ASHTA is an example of a commercial project (shopping mall), for which we not only designed all signage, but also interior elements such as waste bins, planters and information desks, in line with the existing brand identity.

Our work for this project includes overhead signage, amenity signage, floor directories, identification of lift lobbies, elevator-, and escalator-signage, exterior signs on facades, banner poles, lighting poles, project pylons and parking signage.

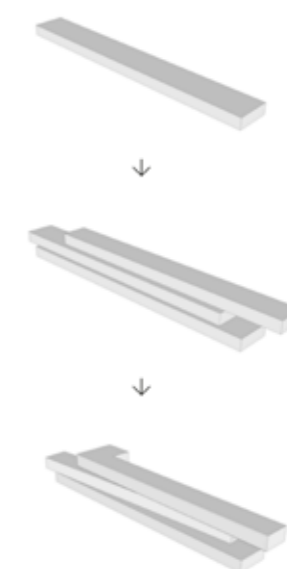

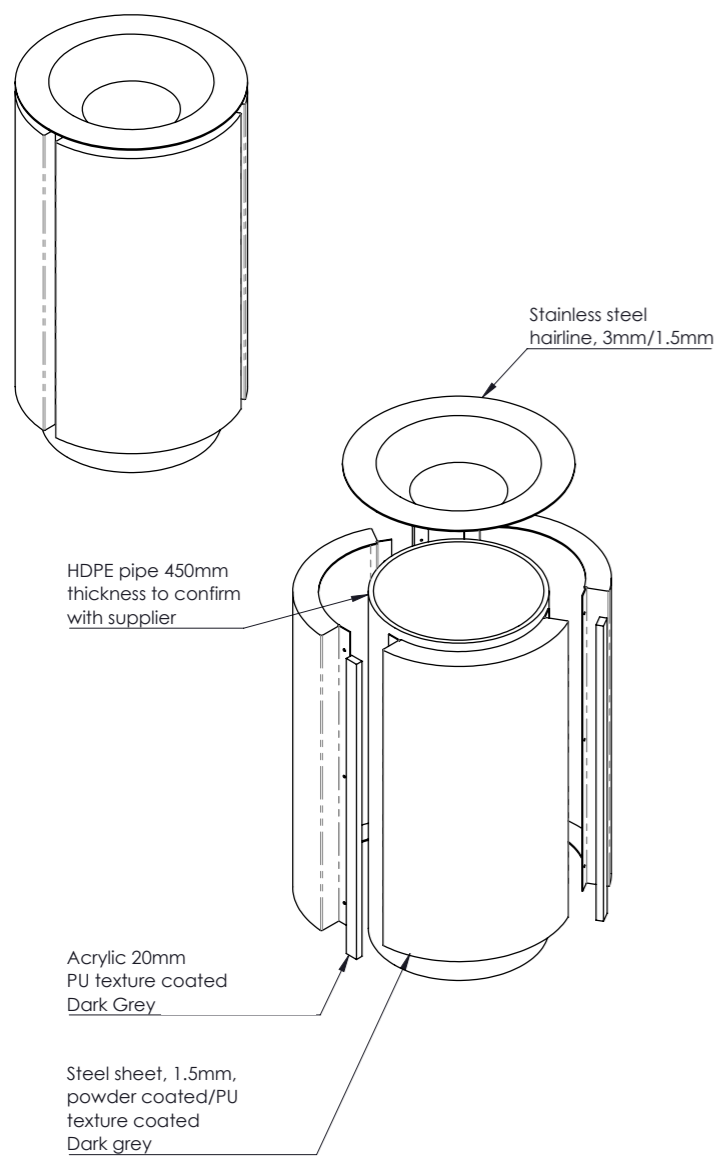



Environmental Graphics

Design of applied graphics to walls and columns, in line with branding and signage guidelines.

The functional graphics provide clear information on the current floor, the location of the parking bay and the flow of traffic. Depending on the nature of the project, the graphics can be more aesthetic or branding oriented. Special projects we have worked on include mosaic and carpet designs (coming soon).

Our Team

The indigo team consists of 13 young professionals that all share a passion for good design. We enjoy our work and we happily go the extra mile to make sure our client is satisfied!



Paul Hessel
Director

Born and raised in the Netherlands, Paul holds a bachelor degree from AIVE (Nowadays known as The Design Academy) in Eindhoven. Shortly after graduating in 1995 he was invited for a short term design project in Indonesia. He fell in love with the country, settled in Jakarta and built himself a career.

He specialises in product design and has a keen interest in graphic design. With 25 years experience in the design business, Paul is the axle of Indigo, integrating the different disciplines into a well functioning team.

Nurlandia Mhas
General Affair

Nurlandia (Didi) attended Universitas Mercu Buana, Jakarta and graduated in 2012 with a D3 title in Accounting. Didi joined Indigo in 2013 and has since been responsible for our administration, billing, and day to day office management.

Alexander Surya
Architect

Alex graduated from Tarumanagara University Indonesia in 2018 with a bachelor degree in architecture. He joined in 2018 as an architect and has since been responsible for developing key plans and handling technical matters.

Farah Jufri
Account Executive

Farah holds a bachelor degree from BINUS University in Jakarta. She majored in Architecture and graduated in 2017. Farah joined Indigo in 2018 and is responsible for project coordination.

Mariane Tanor
Interior Designer

Ane graduated from Trisakti in 2017 with an S1 degree in Interior Design. She joined Indigo in 2019. Ane is part of our design team and communicates with our client's interior designers.

Tasia Loekito
Senior Graphic Designer

Tasia graduated from Nanyang Academy of Fine Arts Singapore in 2013, with a degree in Design and Media. She continued her studies at UPH Surabaya, where she graduated as a bachelor of Business Management. She joined indigo in 2019.

Arzani Arliano
Junior Graphic Designer

Our latest addition to the team, Arzan graduated in 2015 from SMK Negeri 2 in Bogor with a D1 degree in architecture. With a keen interest in graphic design He joined Indigo in 2021.

Ghiffari Haris
Senior Graphic Designer

Ghiffari enrolled at the Raffles Design Institute in Jakarta to study graphic design in 2014. He continued his studies in Sydney, Australia where he graduated as a Bachelor of Visual Communication Design in 2016. In 2018 he returned to Jakarta and joined Indigo.

Mohammad Hamdan
Technical Drafter

Mohammad studied drafting at SMK Pembangunan D1. He has over 10 years experience as a civil drafter. Before joining Indigo in 2019 he worked for BAM International. Hamdan is responsible for our working drawings.

Rinaldi Fajrinnaski
Graphic Designer

Aski holds a degree in economics from Universitas Islam Indonesia. He graduated in 2017, but choose to develop his talents in graphic design. He joined in Indigo 2019.

Fiqih Qorina
3D Artist

Fiqih has mastered the art of creating realistic 3D renderings. She joined the team in 2015 and has since been responsible for the production of all the 3D images used in our client presentations.

Fikry Girigraha
Graphic Designer

Giri has a degree in economics from Universitas STIE YKPN, where he graduated in 2017. He soon after discovered that he wanted to pursue a career in graphic design. Giri joined Indigo in 2020.

Imam Gozali
Office Support

Imam has been our indispensable supporting staff since 2014. He makes sure our headquarters are clean, comfortable and well stocked. He is also responsible for deliveries of documents and samples.

Our Clients

47

Agung Sedayu Group	MALKA
Agung Sedayu Retail Indonesia	Mayora
Alam Bali International	Merdeka Ronov Indonesia
Arta Jaya Putra	MNC Group
Arzu Utama Realty	MRTJakarta
Brahmayasa Bahtera	Nassim JV Company Ltd
Bumi Parama Wisesa	Multi Pilar Kencana
Ciputra group	NDCA
Daiichi	NFK property
Dasary	Nusa Kirana Real Estate
Design Lab	Sinarmas Land
Droog Design	Office 2000
FKNK Law Firm	Otoritas Jasa Keuangan
FKS Land	Pakuwon Group
FKS Multi Agro	Park Hyatt
Grenslicht	Plaza Indonesia Realty
Gudang Garam Group	Sinarmas Land
Hongkong Land	Sonkimland
HT Land	Summarecon
Infinitie Berkah Energi	Sundaya International
Karya Purna Sejahtera	SWOD
Karyadeka Alam Asri	Tanah Tinggi Nusa Dua
Kino	Tempo Group
Lippo Group	Thinking Room
Lippo Homes	Trimitra Kencana
Lippo Malls	Urban Pilar Melenial

48

Our Projects

INDONESIA

COMMERCIAL

ASHTA
 District 8
 FCC
 FCC Event Space
 FCC Mall
 Gandaria City
 Grand Galaxy
 Green Sedayu
 Hub Life
 Kirana Commercial Avenue
 Kristal Medan
 Lippo Mall Kemang
 Lippo Plaza Medan
 Manna
 MOI
 Pakuwon Mall Bekasi
 Palembang Icon
 PIK Avenue
 Tunjungan Plaza 5
 The Quantis Club
 Uptown Mall BSB

OFFICE

Daiichi
 District 8 Office
 Exim Bank
 FKNK Law Firm
 Green Office Park
 Infinitie
 Mandani Bay Quay
 Mayora Head Office
 MNC Media Tower
 MSIG
 Office 8
 Otoritas Jasa Keuangan
 PIK Office
 Tempo Scan Tower
 The Kensington Office Tower

HOSPITALITY

Hotel Arus
 Hilton Hotel (Green Sedayu)
 Ibis Hotel (PIK)
 Keraton
 Kimpton Villas
 The Langham Jakarta
 Marron Hotel
 Mercure (PIK)
 Novotel (PIK)
 Oakwood (District 8)
 Park Hyatt
 Renaissance (Nusa Dua)
 Renaissance (Uluwatu)
 Swissotel (PIK)

RESIDENTIAL

9 Residence
 Anandamaya
 Asaya Marketing Gallery
 Branz Simatupang
 District 8 Residences
 Green Sedayu Residential
 HAKO
 The Langham Residences
 Lyndon
 Nava Park
 Oakwood (District 8)
 Puri Mansion
 Taman Anggrek Residence
 Verde 2

F&B

All Day Dining at The Langham
 Brownmilk
 Green Sedayu F&B Center
 Lihaga
 Linow
 Nusantara
 Park Hyatt Jakarta
 Summers at The Pool
 The Chinese National
 T'Ang Court

HEALTHCARE

Bogor Senior Hospital
 Tzu Chi Hospital
 Santo Borromeus Hospital

PUBLIC TRANSPORT

MRT Jakarta

INTERNATIONAL

OFFICE

Mandani Bay Quay

PHILIPPINES

RESIDENTIAL

Mandani Bay
 Mandani Bay Quay
 The Marq
 The Nassim

PHILIPPINES

PHILIPPINES

VIETNAM

VIETNAM



Contact Us

Our studio is located in Kemang, South Jakarta.

We'd love to hear from you whether you are an old client, a new client, a potential employee, a friend or just curious. So don't hesitate to get in touch with us.

PHONE & FAX

+62 (0) 217 179 1465

ADDRESS

Gedung Kemang Point L1 #1-02B
Jalan Kemang Raya 3,
Jakarta 12730, Indonesia

EMAIL

info@indigo.co.id

INSTAGRAM

[@indigo.idd](https://www.instagram.com/indigo.idd)